

# STANDARD ROAST HOOD

## FITTING AND USE INSTRUCTIONS

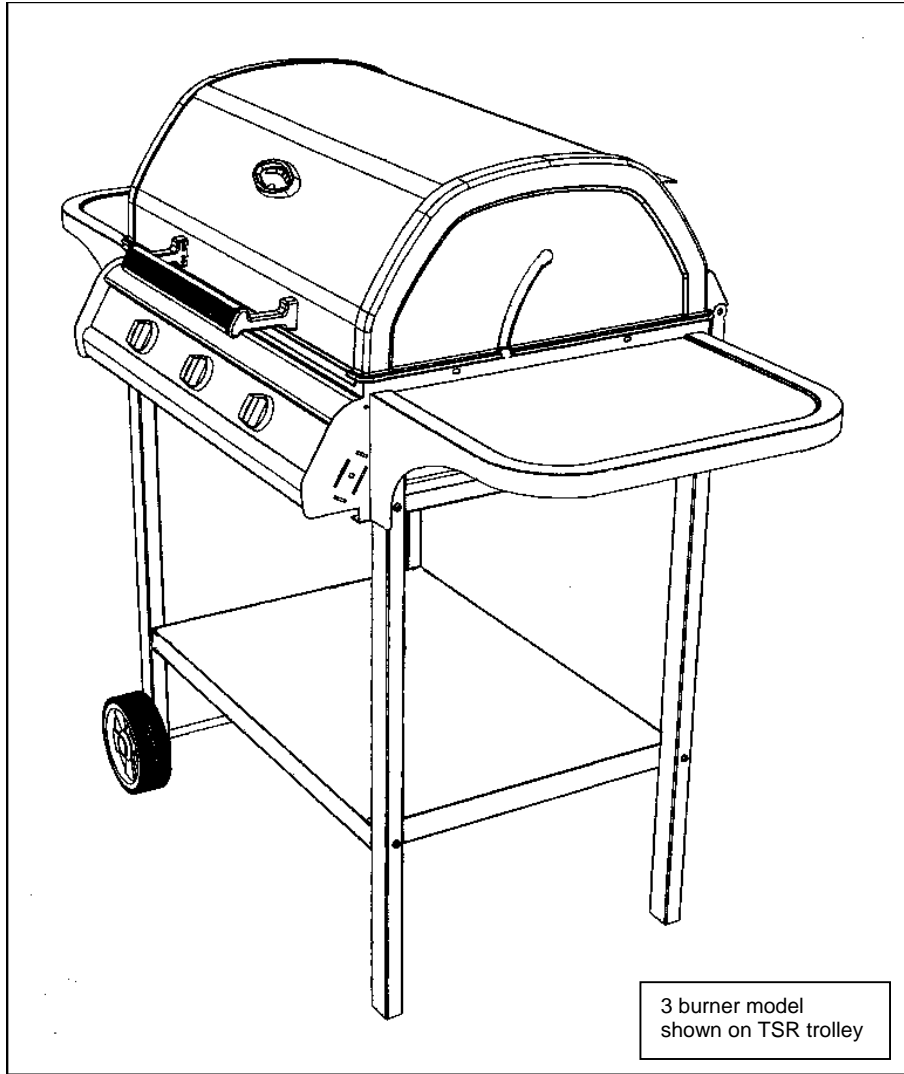

This is a kit-set. Some assembly is required. A small adjustable spanner and a screwdriver are the minimum tools required for assembly.



**A TASTE FOR LIFE**

phone: 0800-800-836

email: [sales.info@glg.co.nz](mailto:sales.info@glg.co.nz)

[www.barbecuefactory.com](http://www.barbecuefactory.com)

**Please read and understand these instructions before beginning assembly.**

Remove all parts from the packaging, lay out on a padded surface and identify and check before commencing assembly. Check for damaged or missing parts. If needed, contact your Dealer.

You should have the following parts:

- 1 pc Assembled Hood body
- 2 pcs Hinge Plates (LH and RH)
- 2 pcs Heat Shields/Rotisserie Brackets
- 2 pcs Hinge Bolts, Spring Washers and Nuts
- 1 pc Handle Assy (aluminum handle and 2 brackets)
- 4 pcs M6x12 Pan Head Screws, Washers and Nuts
- 4 pcs M5x10 Hex Head Bolts, washers and Nuts
- 4 pcs M5x8 Pan Head Screws, Washers and Nuts
- 1 pc Temperature Indicator

To fit the hood to the BBQ, it is first necessary to fit the hinge plates to your BBQ. These are fitted to the inside faces of the BBQ sides at the back, using the two holes, one above the other, about 20mm in from the back. These holes are used for mounting some models of trolley to the BBQ and if they are in use for this, simply undo the nuts and washers of the trolley holding bolts, and fit the hinge plates under them. Otherwise, use the 6mm screws, washers and nuts included in the hardware pack. (Ensure the plates are placed on the correct sides as they are offset slightly and will not fit the hood if incorrectly fitted.) Do not fully tighten the bolts yet. **See Fig 1**

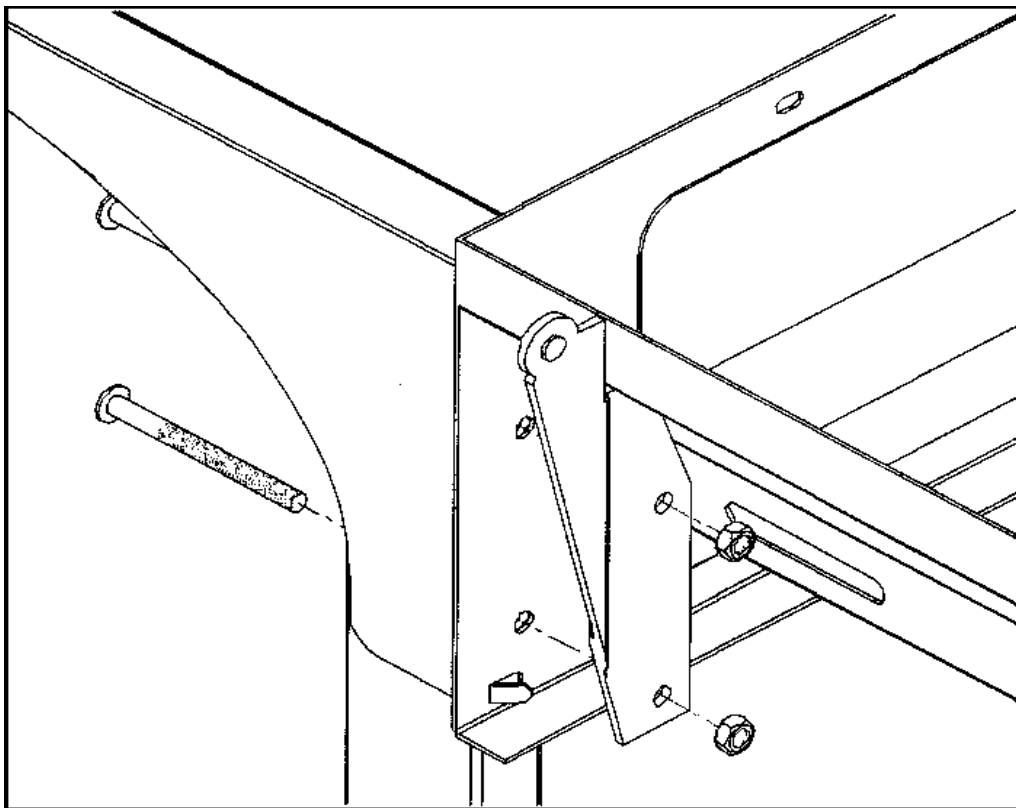

**Fig 1**

Place the hood onto the BBQ body, and align the hinges and hinge plates. Fit the hinge bolts through the hinges and plates and secure with the locking nuts provided. Do not over-tighten the nuts. **See fig 2**

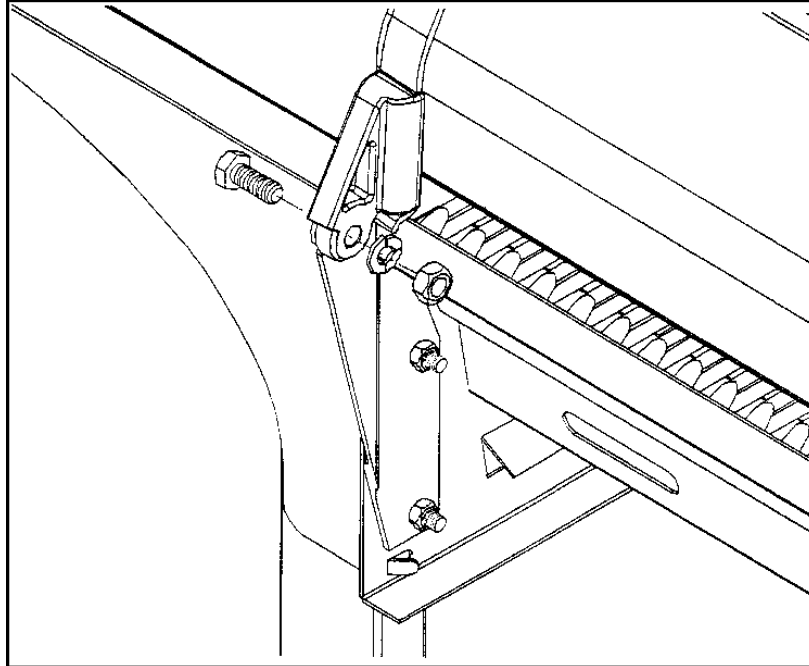

**Fig 2**

Once the hinges are fitted, centralise the hood on the BBQ body and then tighten the bolts holding the hinge plates fully.

Fit the handle to the front of the hood. Lift the lid to its fully open position. Place the **HEADS** of the small hex headed bolts into the recesses of the handle brackets and place through the holes in the panel of the hood. Fit the washers and nuts provided from the inside. Tighten firmly, but not excessively or the hood finish or handle brackets may be damaged. **See Fig 3**

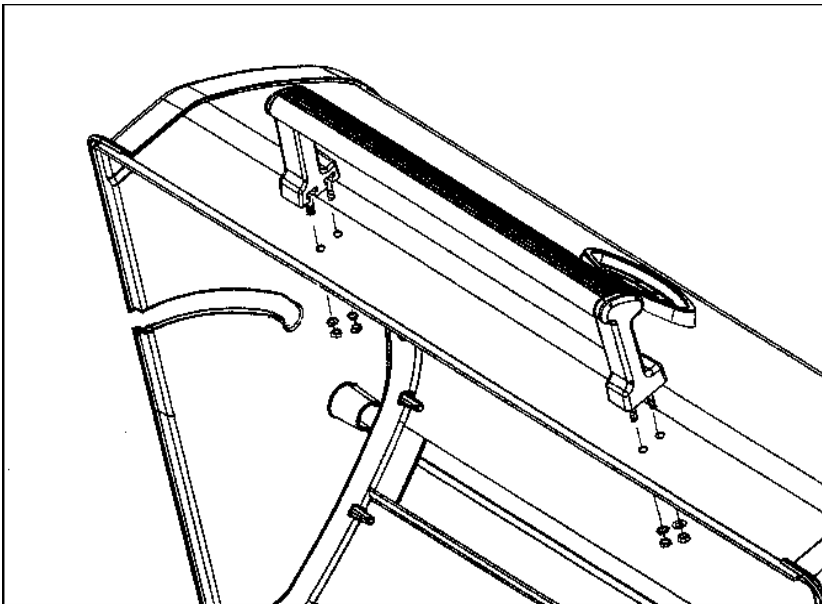

Fit the temperature indicator to the outside of the hood. Place all the washers on the studs from inside the hood. Do not over-tighten the nuts.

**Fig 3**

Fit the Heat Shields/Rotisserie Brackets to the **insides** of the BBQ sides using the M5x 8 screws and nuts. They must be fitted with the offset inside, to allow the hood to close. Adjust the final position of the brackets so that the notches in the tops are centralised in the slots in the side castings. This will allow the motor bracket, when fitted, to clear the side castings as the hood is opened.

**Don't use the hood without these brackets in place. Satisfactory performance will be compromised, and damage may be caused to the trolley.**

### **Use of your roast hood:**

**Note:** Cook-plates must be removed from the BBQ when cooking with the Roast Hood. Use grilles only when cooking with the hood down, to prevent excessive heat build-up which may damage your BBQ or Roast Hood. Do not turn all burners to HIGH for long periods of time. This will result in extremely high temperatures that will damage the BBQ and hood.

It is recommended that a drip pan be used under the food where possible to collect excess juices that could flare up and burn the cooking food.

The best method of cooking is Indirect Cooking, where the burners directly under the food are not used, and the heat source is to one side or both sides of the food. This allows even all-round cooking without having to turn the food.

Cooking will normally require only 2 burners running on LOW or MEDIUM setting, but this will require some trial cooking to determine for sure what is correct for your own recipes and style of cooking. However it is important that all food is cooked properly. Some foods, especially poultry, can cause illness if not fully cooked. It is recommended that a good cookbook specialising in BBQ food is referred to for tips and ideas. Your Dealer will be able to recommend such cook books.

**After cooking**, turn off the BBQ first, as directed in your BBQ Instruction Manual, and only then carefully lift the lid. Keep your face away from the lid when opening it as a wave of very hot air will vent out of the lid when it is lifted. ***Use oven gloves or mitts to avoid burning yourself on hot surfaces.***